

1964 - 2024

IMAC

love your pet



Criceti 16

→ 80 ↙ 48,5 ↑ 37,5 cm



imac.it

Istruzioni di montaggio - Assembly instructions - Instructions de montage Aufbau-Anleitung - Instrucciones de montaje - Инструкция по сборке Instructiuni de asamblare

Prodotto e Distribuito da / Produced and Distributed by / Fabriqué et distribué par / Hergestellt und Vertrieb durch / Producido y distribuido por / Производство и распространение / Producs de:

IMAC s.r.l. Unipersonale - Via Ghisa, 24 - 36071 Tezze di Arzignano (VI) ITALY
 Tel. +39 0444 482301 - info@imac.it - www.imac.it



Verifica le disposizioni del tuo comune - Check local recycling requirement

MATERIALE: plastica, ferro / MATERIAL: plastic, iron / MATERIAUX: plastique, métal / MATERIAL: Plastik, Eisen / MATERIAL: Plástico, Hierro / МАТЕРИАЛ: пластик, железо / MATERIAL: Plastic, Metal

IT Articollo per animali da compagnia. Tenere lontano dalla portata dei bambini. Se danneggiato sostituirlo. In caso di ingestione, anche di piccole parti, contattare immediatamente un veterinario. EN Item for pets. Keep out of reach of children. Replace if damaged. In case of ingestion, even small parts, immediately contact a veterinarian. FR Produits pour animaux de compagnie. Tenir hors de portée des enfants. Remplacer si abimé. En cas d'ingestion, même d'une petite partie, contactez immédiatement un vétérinaire. DE Produkte für Tiere. Außerhalb der Reichweite von Kindern aufbewahren. Bei Beschädigung ersetzen. Im Fall von Verschlucken, auch kleinster Teilchen, bitte sofort einen Tierarzt kontaktieren. ES Elemento para mascotas. Mantener fuera del alcance de los niños. Reemplazar en caso de daño. En caso de ingesta de los elementos pequeños, contacte inmediatamente con un veterinario. RU Товар для домашних животных. Хранить в недоступном для детей месте. При повреждении заменить. В случае проглатывания мелких деталей необходимо немедленно обратиться к ветеринару. RO Articol pentru animale de companie. A nu se lăsa la îndemâna copiilor. Înlocuiți-l dacă este deteriorat. În caz de ingestie, chiar și a unor părți mici, contactați imediat un medic veterinar.

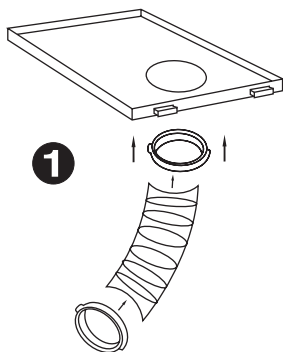

1

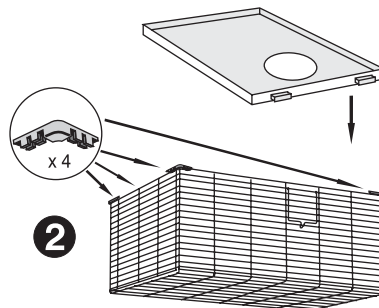

2

Capovolgere la gabbia per fissare i ripiani.
 To turn upside down the cage to attach the platforms.

Posizionare i ripiani su 3° filo dal basso.
 Position the platforms on the 3rd row from bottom.

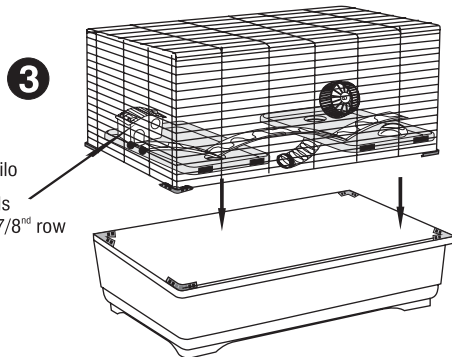

3

Posizionare i bottoni della scaletta sul 7/8° filo

Position the press-studs for small staircase on 7/8nd row



Posizionare le clips sul 5° filo
 Position the clips on 5nd row

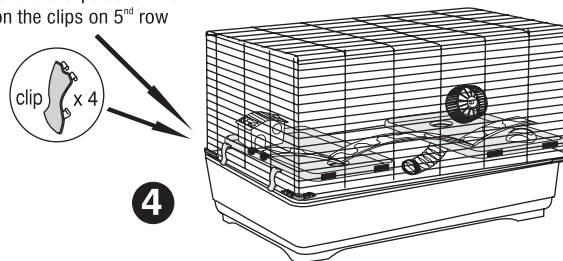

4

imac.it